

Pair of Chrome Pineapple Touch Lamps with Grey Shades



## LIGHT SOURCE DATA

- 2 x 60W Max E14 SES (required)
- Lamp direction - Indirect
- Lamp shape - Standard
- Non-dimmable
- Energy class: Not applicable

## DIMENSION DATA

- Height 420mm
- Diameter 220mm
  
- Weight 1.9kg

## SPECIFICATION

- Manufacturer warranty for 2 years from date of purchase
- Polished chrome plate with crystal effect glass detail and grey cotton
- IP20
- Touch On/Off Switch
- Class II - Double Insulated, No Earth
- 240V
- Assembly required? No
- UKCA Marking, Energy Efficient, Energy Saving

## CERTIFICATION



## CONTACT

[www.firstchoicelighting.co.uk](http://www.firstchoicelighting.co.uk)

[info@firstchoicelighting.co.uk](mailto:info@firstchoicelighting.co.uk)

# FCL-10796X2

Pair of Chrome Pineapple Touch Lamps with Grey Shades

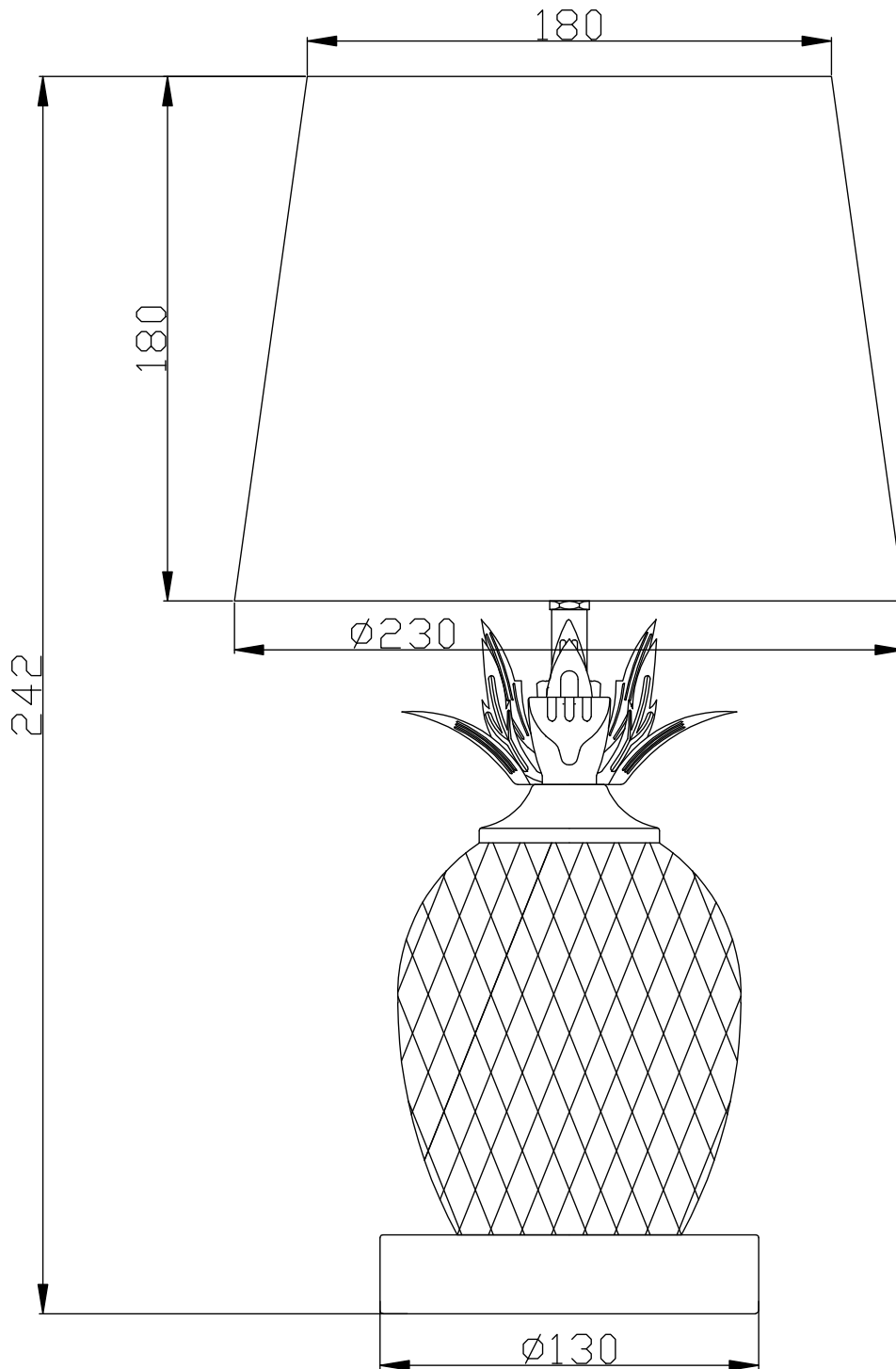

## CERTIFICATION



## CONTACT

[www.firstchoicelighting.co.uk](http://www.firstchoicelighting.co.uk)

[info@firstchoicelighting.co.uk](mailto:info@firstchoicelighting.co.uk)