

Set of 2 Halo - Stainless Steel Outdoor IP44 Motion Sensor Wall Lights



LIGHT SOURCE DATA

- 2 x 60W Max E27 ES (required)
- Lamp direction - Downwards
- Lamp shape - Standard
- Non-dimmable
- Energy class: Not applicable

DIMENSION DATA

- Height 300mm
- Width 180mm
- Depth 220mm
- Weight 0.83kg

SPECIFICATION

- Manufacturer warranty for 2 years from date of purchase
- Brushed stainless steel and clear PC
- IP44
- No
- PIR Motion Sensor
- Detection angle: 90. Detection range: 8m. Lux: 10 to 20000. Operating temp: -20 to 40. Timer function: 5 sec to 5 min. Wall mount: 1.8m. Override: No override function.
- Class I - Single Insulated, Earthed
- 240V
- Assembly required? No
- UKCA Marking, Energy Efficient, Energy Saving

CERTIFICATION



CONTACT

www.firstchoicelighting.co.uk

info@firstchoicelighting.co.uk

FCL-12717X2

Set of 2 Halo - Stainless Steel Outdoor IP44 Motion Sensor Wall Lights

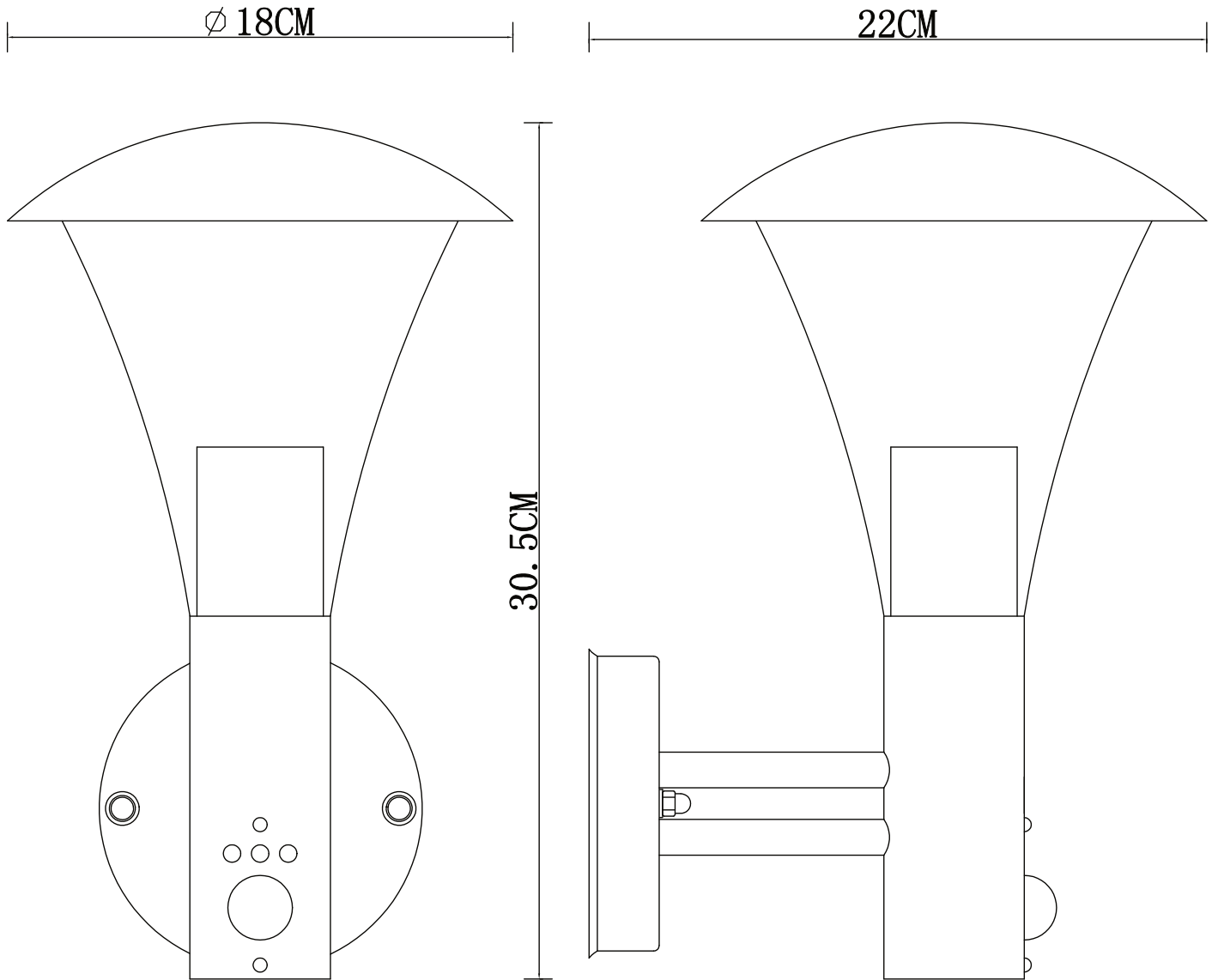

CERTIFICATION



CONTACT

www.firstchoicelighting.co.uk

info@firstchoicelighting.co.uk