

Wilson - Concrete Lamp with White Fabric Shade



LIGHT SOURCE DATA

- 40W Max E14 SES (required)
- Lamp direction - Indirect
- Lamp shape - Standard
- Non-dimmable
- Energy class: Not applicable

DIMENSION DATA

- Height 270mm
- Diameter 160mm

- Weight 0.80kg

SPECIFICATION

- Manufacturer warranty for 2 years from date of purchase
- Grey concrete and white cotton
- IP20
- In-line On/Off Switch
- Class II - Double Insulated, No Earth
- 240V
- Assembly required? No
- 1.3m length cable from base to plug
- UKCA Marking, Energy Efficient, Energy Saving

CERTIFICATION



CONTACT

www.firstchoicelighting.co.uk

info@firstchoicelighting.co.uk

FCL-13345

Wilson - Concrete Lamp with White Fabric Shade

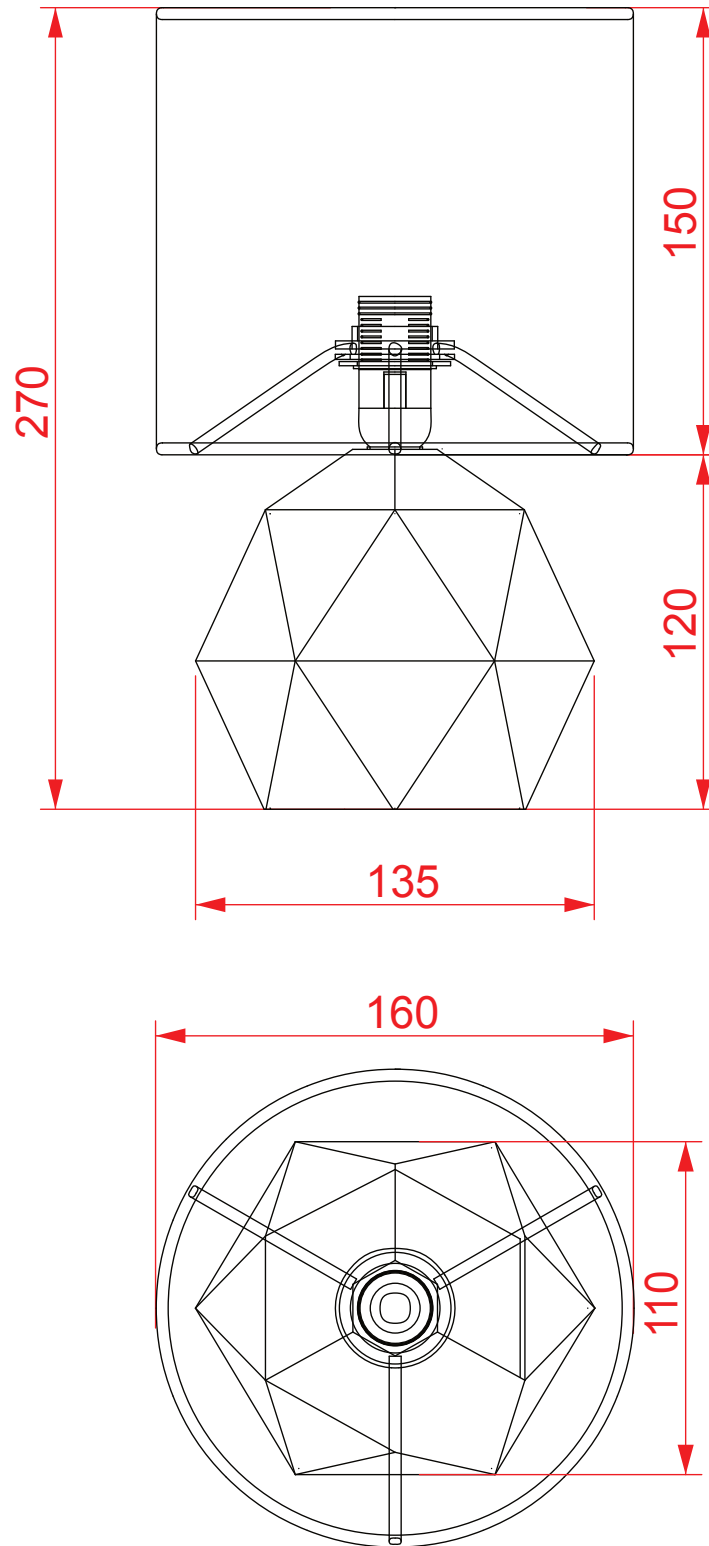

CERTIFICATION



CONTACT

www.firstchoicelighting.co.uk

info@firstchoicelighting.co.uk

ISSUE DATE 09/03/2026

PAGE 2