



LIGHT SOURCE DATA

- 60W Max E27 ES (required)
- Lamp direction - Upwards
- Lamp shape - Standard
- Dimmable
- Energy class: Not applicable

DIMENSION DATA

- Height 1000mm
- Width 150mm
- Depth 170mm

- Weight 1.00kg

SPECIFICATION

- Manufacturer warranty for 2 years from date of purchase
- Matt black and clear glass
- IP44
- No
- Class I - Single Insulated, Earthed
- 240V
- Assembly required? No
- Powder coated with pre-treatment for outdoor use
- UKCA Marking, Energy Efficient, Energy Saving

CERTIFICATION



CONTACT

www.firstchoicelighting.co.uk

info@firstchoicelighting.co.uk

FCL-20966

Cambridge - Black & Clear Glass Lantern IP44 Outdoor 100cm Post Light

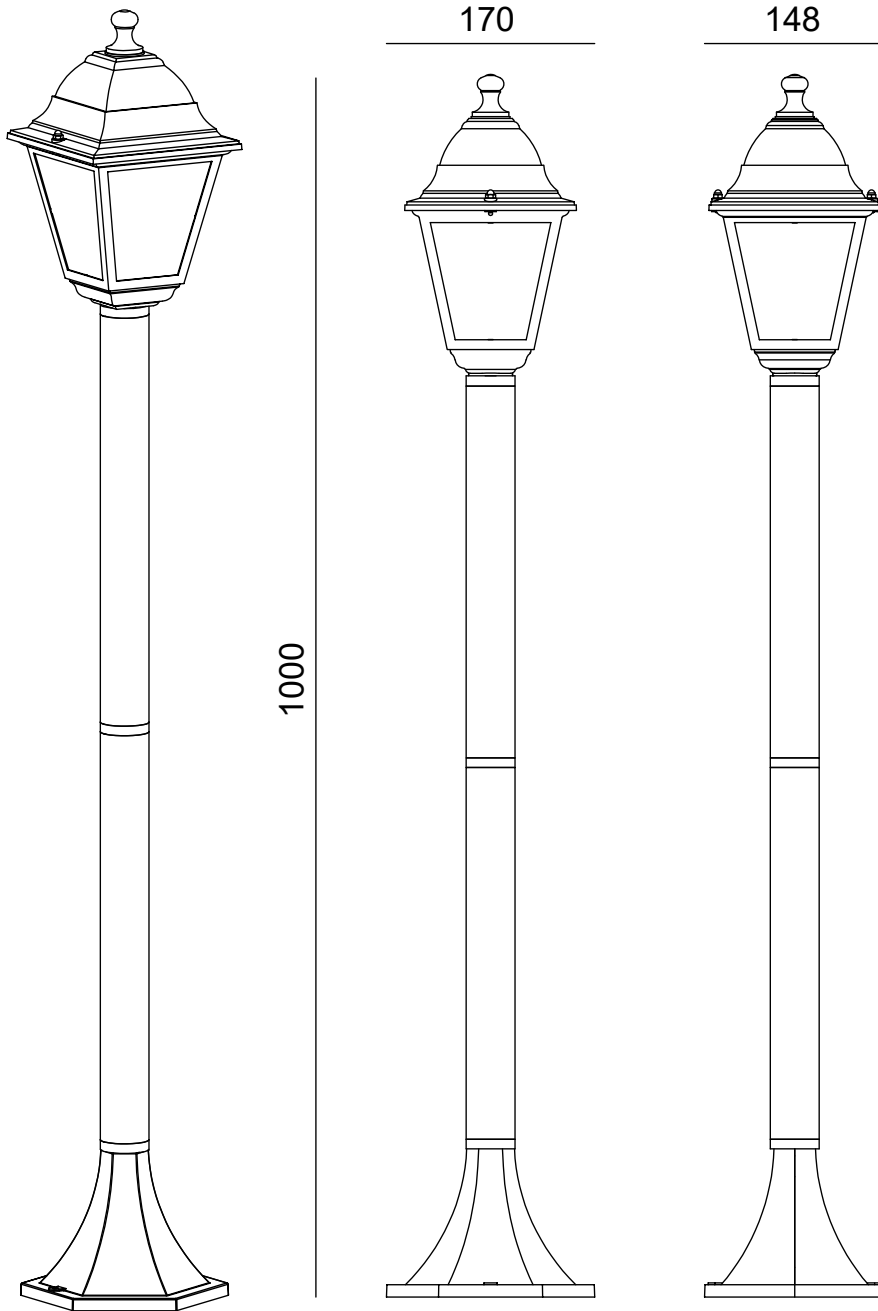

CERTIFICATION



CONTACT

www.firstchoicelighting.co.uk

info@firstchoicelighting.co.uk

ISSUE DATE 16/03/2026

PAGE 2