

Set of 2 Sundance - Chrome Tripod Table Lamps with Green Pleated Shade



LIGHT SOURCE DATA

- 2 x 40W Max E14 SES (required)
- Lamp direction - Indirect
- Lamp shape - Conical/Candelabra/Candle
- Non-dimmable
- Energy class: Not applicable

DIMENSION DATA

- Height 540mm
- Diameter 250mm

- Weight 0.80kg

SPECIFICATION

- Manufacturer warranty for 2 years from date of purchase
- Polished chrome plate and green pleated velvet with gold cardboard inner detail
- IP20
- In-line On/Off Switch
- Class II - Double Insulated, No Earth
- 240V
- Assembly required? No
- UKCA Marking, Energy Efficient, Energy Saving

CERTIFICATION



CONTACT

www.firstchoicelighting.co.uk

info@firstchoicelighting.co.uk

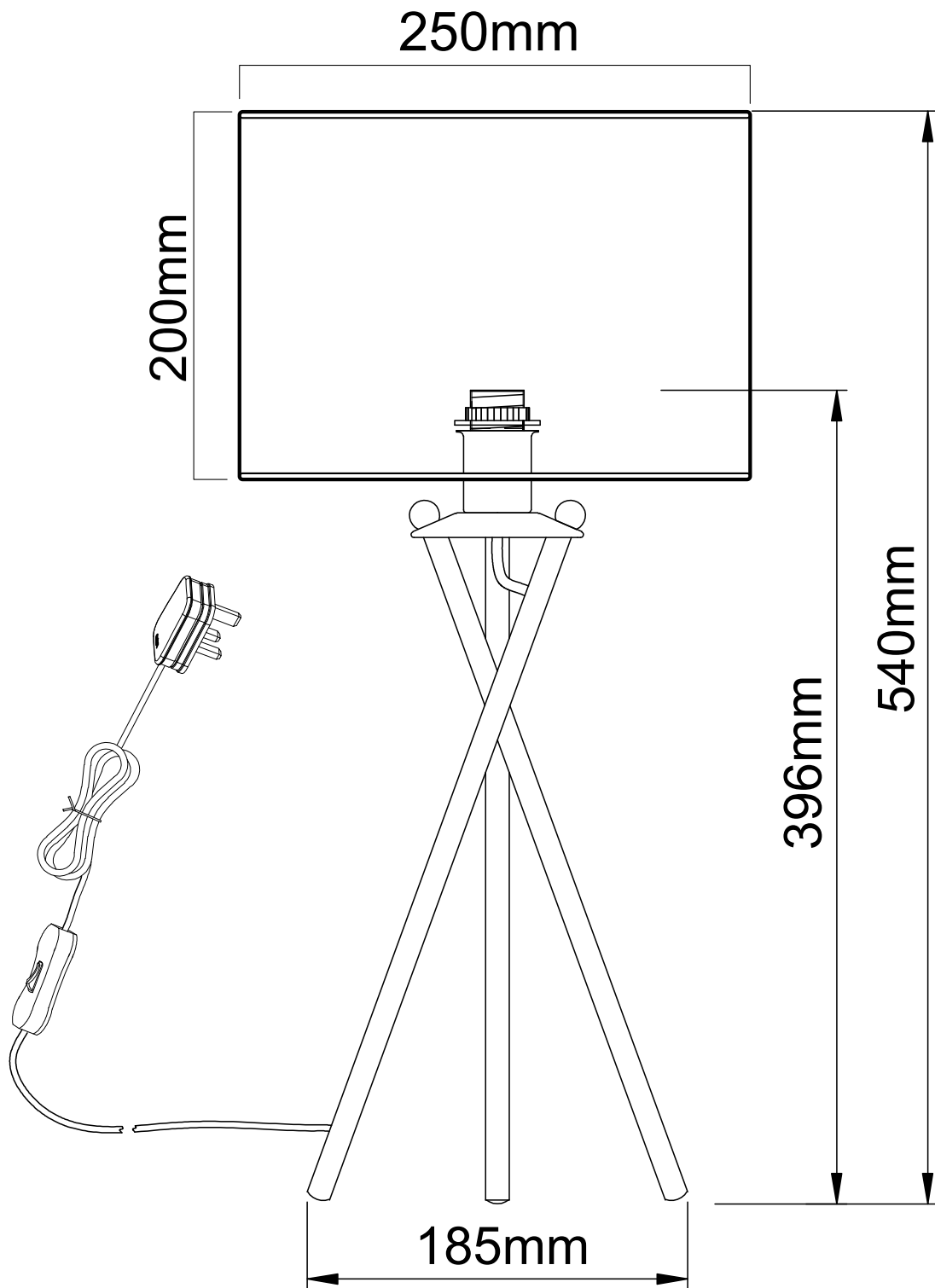

CERTIFICATION



CONTACT

www.firstchoicelighting.co.uk

info@firstchoicelighting.co.uk