

Chrome Two Ball Table Lamp with Burgundy Fern Shade



## LIGHT SOURCE DATA

- 5W Max LED E14 SES (required)
- Lamp shape - Standard
- Non-dimmable
- Energy class: Not applicable

## DIMENSION DATA

- Height 330mm
- Diameter 155mm
- Weight 0.50kg

## SPECIFICATION

- Manufacturer warranty for 2 years from date of purchase
- Polished chrome plate with clear acrylic detail and burgundy cotton
- IP20
- In-line On/Off Switch
- Class II - Double Insulated, No Earth
- 240V
- Assembly required? No
- UKCA Marking, Energy Efficient, Energy Saving

## CERTIFICATION



## CONTACT

[www.firstchoicelighting.co.uk](http://www.firstchoicelighting.co.uk)

[info@firstchoicelighting.co.uk](mailto:info@firstchoicelighting.co.uk)

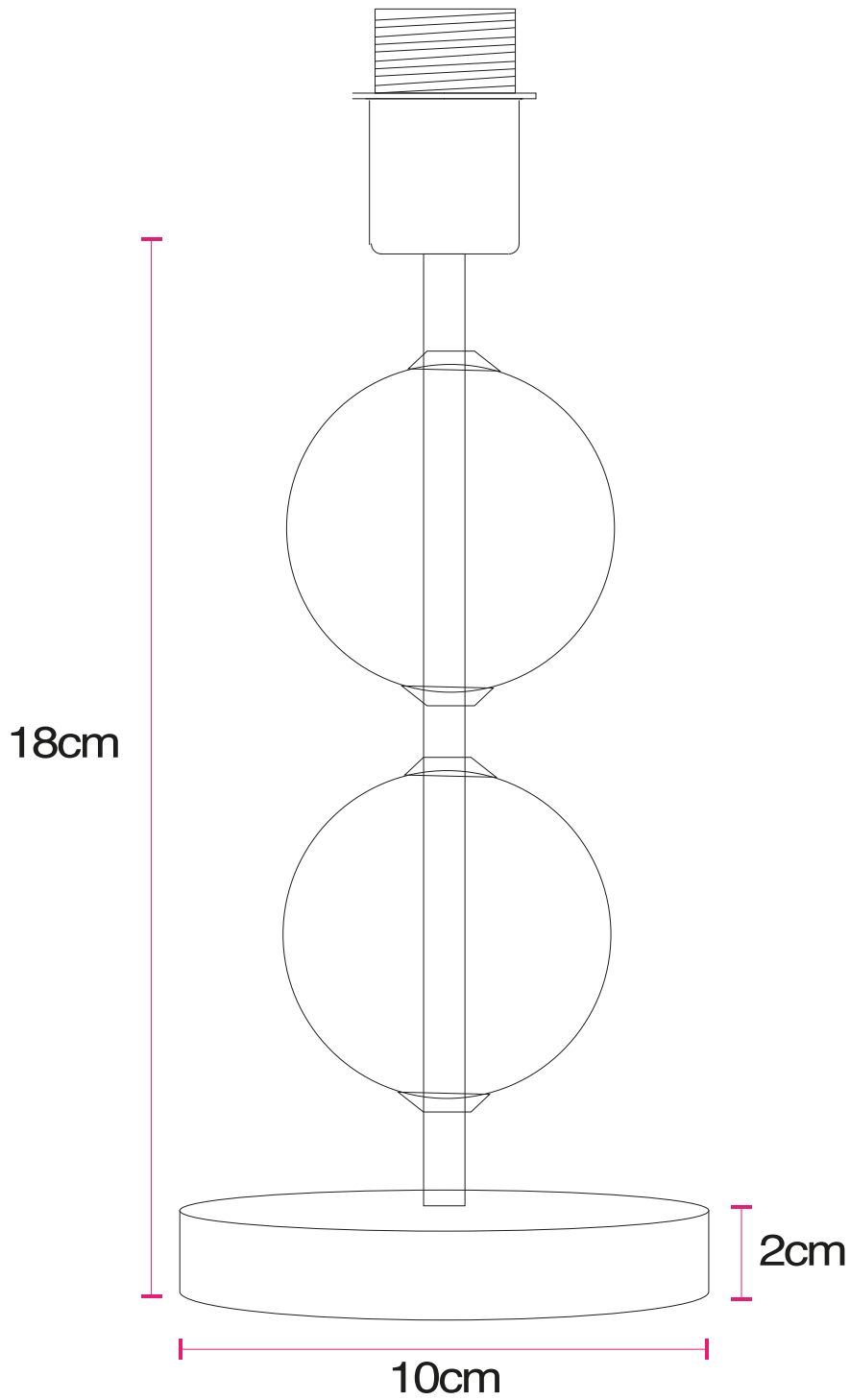

## CERTIFICATION



## CONTACT

[www.firstchoicelighting.co.uk](http://www.firstchoicelighting.co.uk)

[info@firstchoicelighting.co.uk](mailto:info@firstchoicelighting.co.uk)