

Set of 2 Brea - Chrome Wall Light Fittings Only



LIGHT SOURCE DATA

- 2 x 40W Max E14 SES (required)
- Lamp direction - Indirect
- Lamp shape - Standard
- Dimmable
- Energy class: Not applicable

DIMENSION DATA

- Height 150mm
- Width 100mm
- Depth 150mm

- Weight 0.80kg

SPECIFICATION

- Manufacturer warranty for 2 years from date of purchase
- Polished chrome plate
- IP20
- No
- Class I - Single Insulated, Earthed
- 240V
- Assembly required? No
- UKCA Marking, Energy Efficient, Energy Saving

CERTIFICATION



CONTACT

www.firstchoicelighting.co.uk

info@firstchoicelighting.co.uk

FCL-26057X2

Set of 2 Brea - Chrome Wall Light Fittings Only

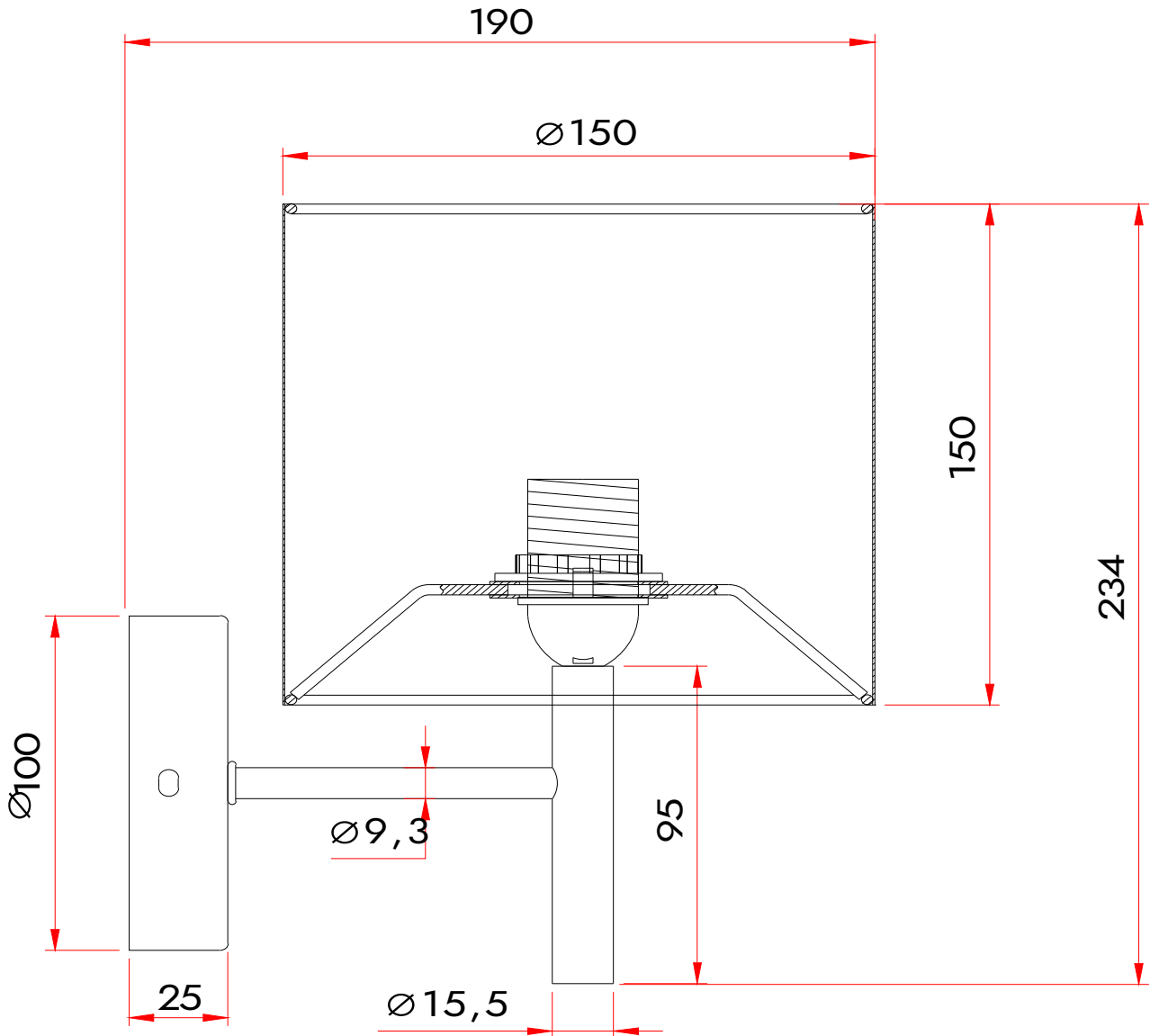

CERTIFICATION



CONTACT

www.firstchoicelighting.co.uk

info@firstchoicelighting.co.uk