

Brea - Antique Brass 3 Arm Semi Flush Fitting Only



LIGHT SOURCE DATA

- 3 x 40W Max E14 SES (required)
- Lamp direction - Indirect
- Lamp shape - Standard
- Dimmable
- Energy class: Not applicable

DIMENSION DATA

- Height 425mm
- Diameter 405mm

- Weight 1.50kg

SPECIFICATION

- Manufacturer warranty for 2 years from date of purchase
- Antique brass plate
- IP20
- No
- Class II - Double Insulated, No Earth
- 240V
- Assembly required? No
- UKCA Marking, Energy Efficient, Energy Saving

CERTIFICATION



CONTACT

www.firstchoicelighting.co.uk

info@firstchoicelighting.co.uk

Brea - Antique Brass 3 Arm Semi Flush Fitting Only

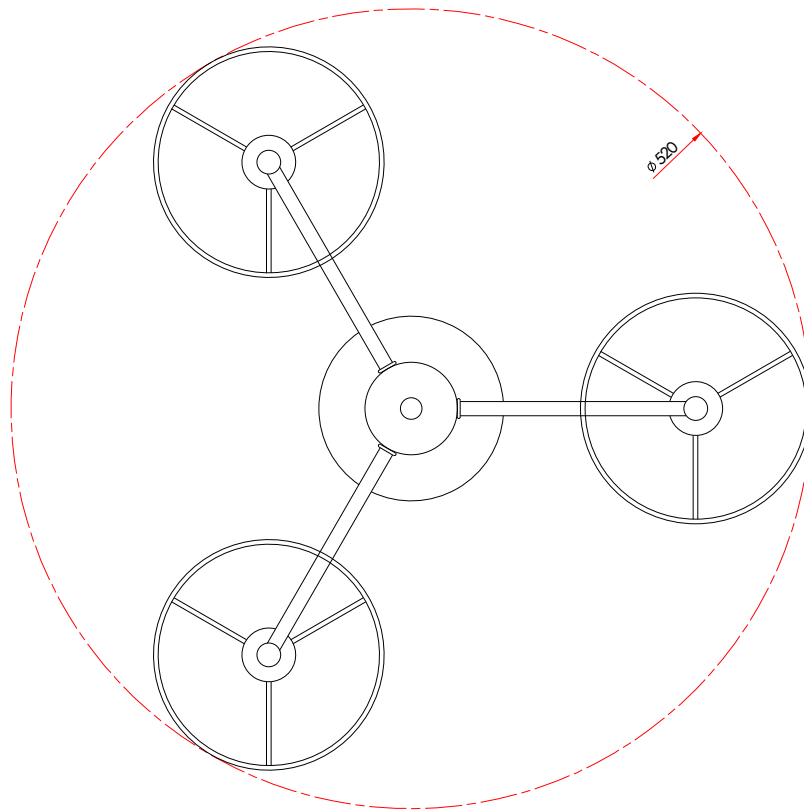
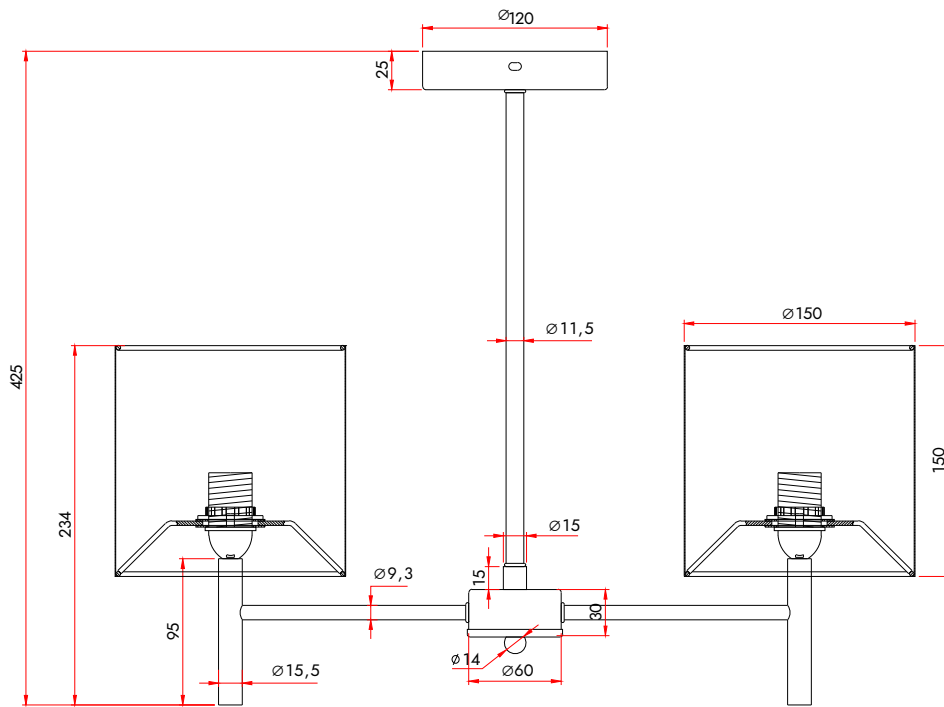

CERTIFICATION



CONTACT

www.firstchoicelighting.co.uk

info@firstchoicelighting.co.uk