

Installation and Safety Instructions

M & C Floor Light

Safety Warnings

These instructions are for your safety. Please read through them thoroughly before use and retain them for future reference. If you are in any doubt about installing this product, consult a qualified electrician.

This product is only suitable for connection to a 220-240V~ 50Hz supply. It is for indoor use only, and not suitable for a bathroom location.

This is a Class I product and must be Earthed.

Do not attempt to plug in or use this product until it has been fully assembled. Disconnect from mains during assembly or maintenance. this product must be used on a stable, flat surface.

Under no circumstances must this floor lamp be covered with any material as this could pose a safety hazard. This product is not suitable for persons under 14 years of age.

This product may contain delicate parts – be careful during handling and maintenance to avoid breakage.

The lamp must be protected by a 3 amp fuse in the mains plug.

Never fit bulbs of a higher wattage than those specified on the label as these may damage the fitting.

Never put anything on the product or hang anything on any part of this product.

If the external flexible cable or cord of this luminaire is damaged, it must only be replaced by a qualified electrician to avoid any electrical hazards.

Waste electrical products should not be disposed of with household waste. Please recycle where facilities exist. Check with your Local Authority or local store for recycling advice.

Care and maintenance

The shade and lamp become very hot in use. Switch off and allow 10 minutes to cool before replacing bulb, adjusting or cleaning (using a dry cloth only - do not use liquid or abrasive cleaners).

Troubleshooting

When the bulb does not light after installation:

- > Please plug in and operate the dimmer switch to turn your lamp on.
- > Please check the bulb.
- > Please check the 3 amp fuse in the plug and ultimately check the relevant fuse in your fuse box.

If you have any doubt about installation/use of this product, consult a qualified electrician.

Assembly Instructions

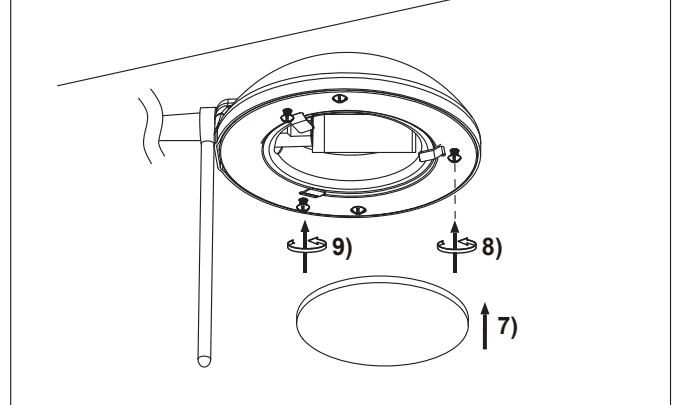
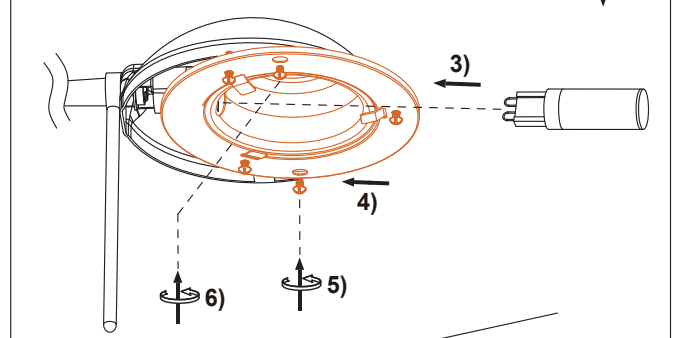
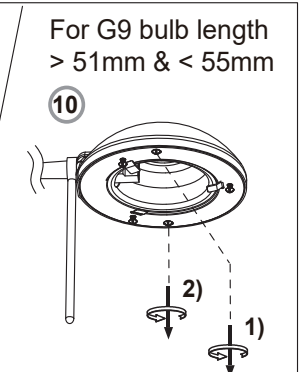
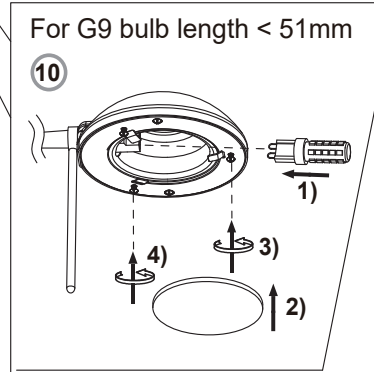
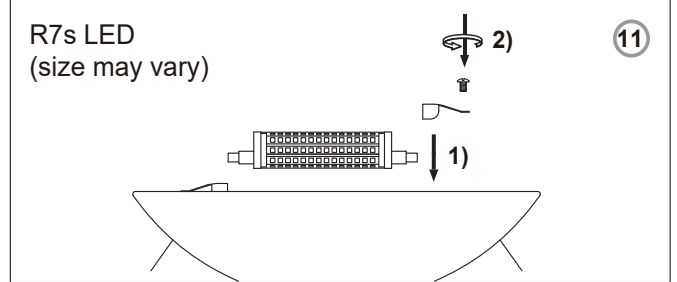
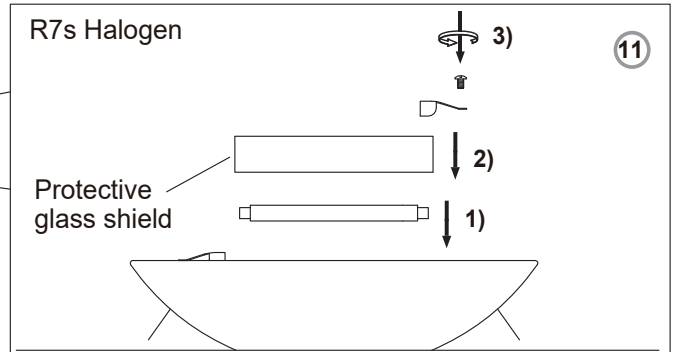
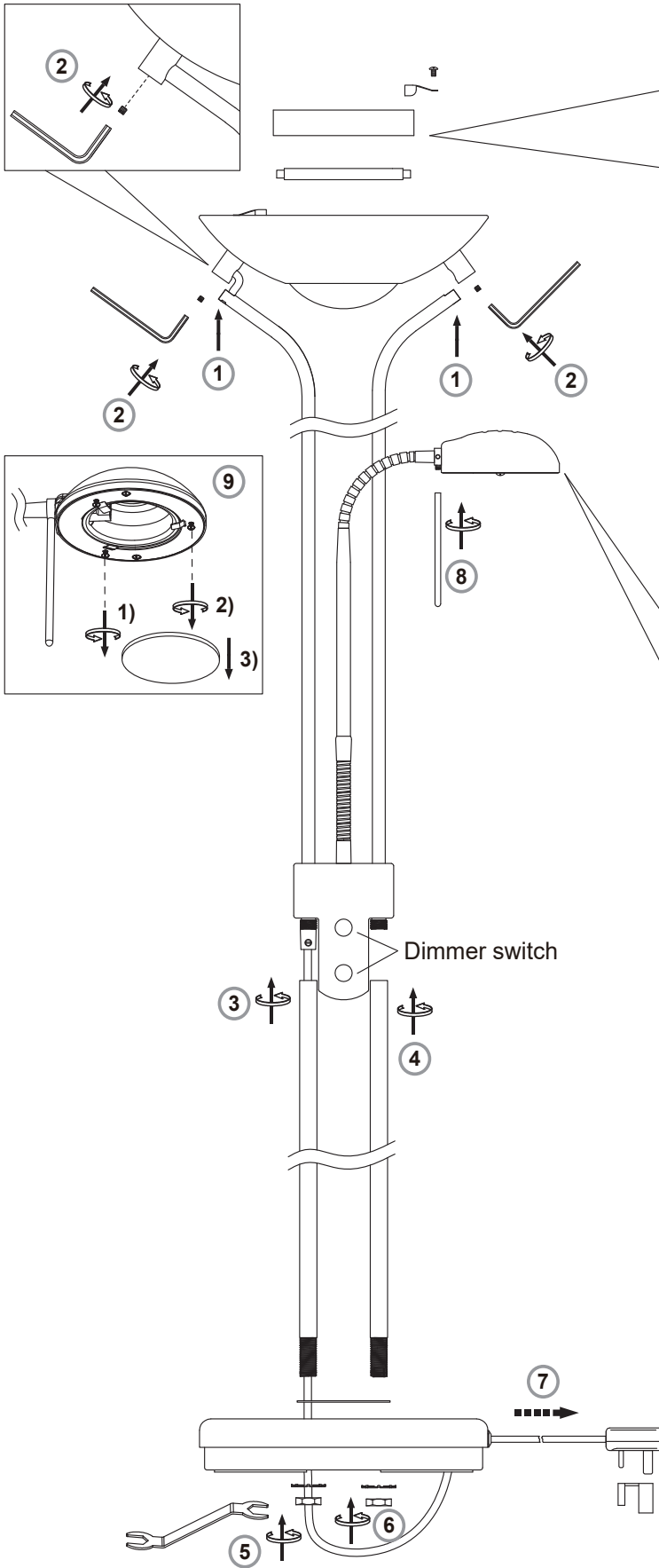

- EN Scan QR code for multi-language
- FR Scannez le code QR pour plusieurs langues
- ES Escanee el código QR para varios idiomas
- PL Zeskanuj kod QR dla wielu języków
- DE Scannen Sie den QR-Code nach mehreren Sprachen
- IT Scansiona il codice QR per multilingua



UK Manufacturer: BH17 7BY
EU Manufacturer: Brilliant AG,
Brillantstrasse 1, D-27442 Gnarrenburg