



LIGHT SOURCE DATA

- 40W Max E27 ES (required)
- Lamp direction - Indirect
- Lamp shape - Standard
- Dimmable
- Energy class: Not applicable

DIMENSION DATA

- Height 280mm
- Width 115mm
- Depth 150mm

- Weight 0.94kg

SPECIFICATION

- Manufacturer warranty for 2 years from date of purchase
- Anthracite and clear glass diffuser
- IP23
- No
- Class I - Single Insulated, Earthed
- 240V
- Assembly required? No
- UKCA Marking, Energy Efficient, Energy Saving

CERTIFICATION



CONTACT

www.firstchoicelighting.co.uk

info@firstchoicelighting.co.uk

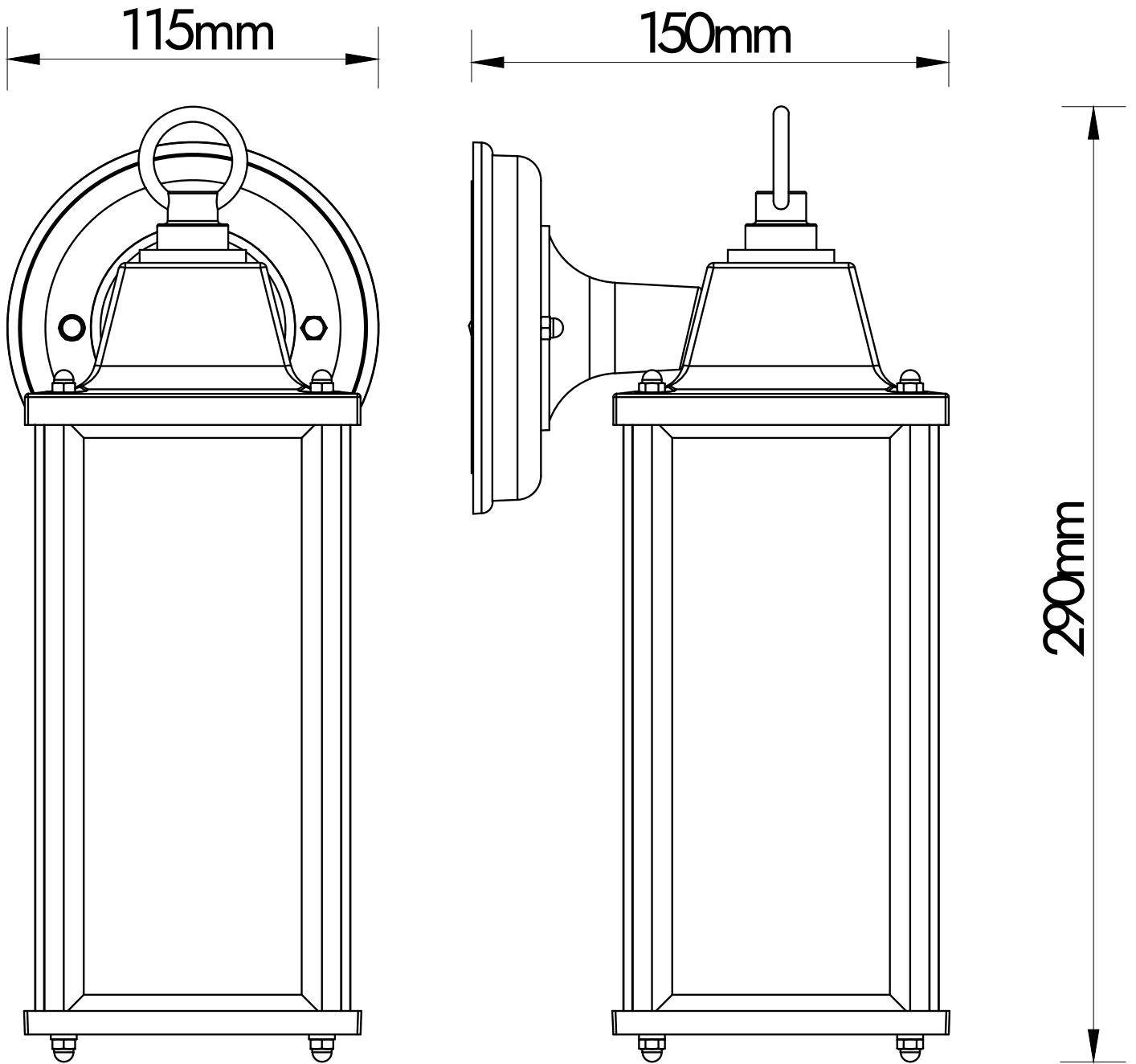

CERTIFICATION



CONTACT

www.firstchoicelighting.co.uk

info@firstchoicelighting.co.uk