



LIGHT SOURCE DATA

- 15W Max LED E27 ES (required)
- Lamp direction - Indirect
- Lamp shape - Standard
- Dimmable
- Energy class: Not applicable

DIMENSION DATA

- Height 295mm
- Width 145mm
- Depth 175mm
- Weight 0.98kg

SPECIFICATION

- Manufacturer warranty for 2 years from date of purchase
- Black and clear PC
- IP44
- No
- Class I - Single Insulated, Earthed
- 240V
- Assembly required? No
- UKCA Marking, Energy Efficient, Energy Saving

CERTIFICATION



CONTACT

www.firstchoicelighting.co.uk

info@firstchoicelighting.co.uk

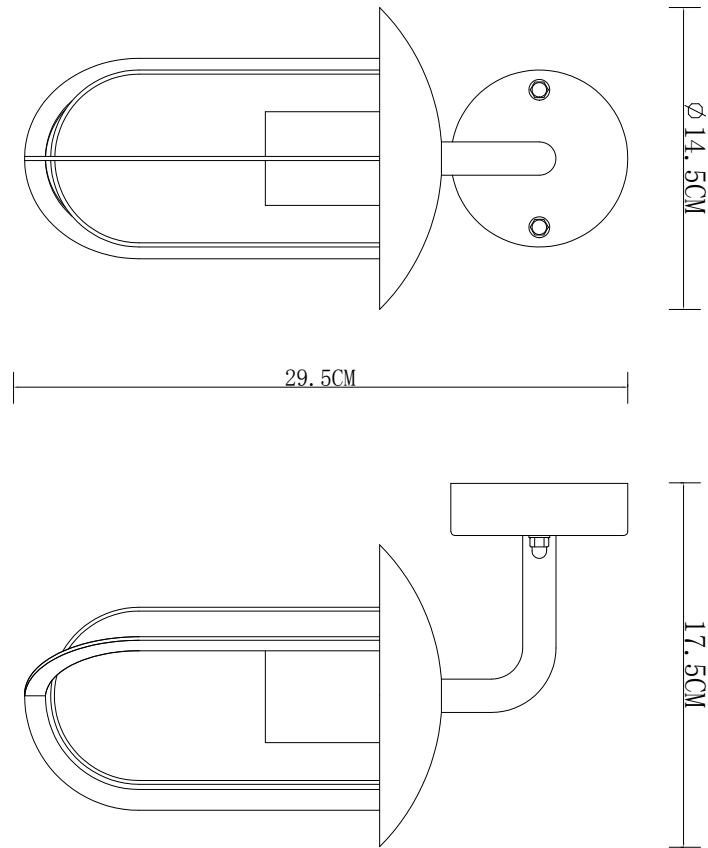

CERTIFICATION



CONTACT

www.firstchoicelighting.co.uk

info@firstchoicelighting.co.uk