



LIGHT SOURCE DATA

- 40W Max G9 Halogen (required)
- Lamp direction - Downwards
- Lamp shape - Capsule
- Dimmable
- Energy class: Not applicable

DIMENSION DATA

- Height 95mm
- Width 75mm
- Depth 90mm

- Weight 0.60kg

SPECIFICATION

- Manufacturer warranty for 2 years from date of purchase
- White plaster
- IP20
- No
- Class II - Double Insulated, No Earth
- 240V
- Assembly required? No
- UKCA Marking, Energy Efficient, Energy Saving

CERTIFICATION



CONTACT

www.firstchoicelighting.co.uk

info@firstchoicelighting.co.uk

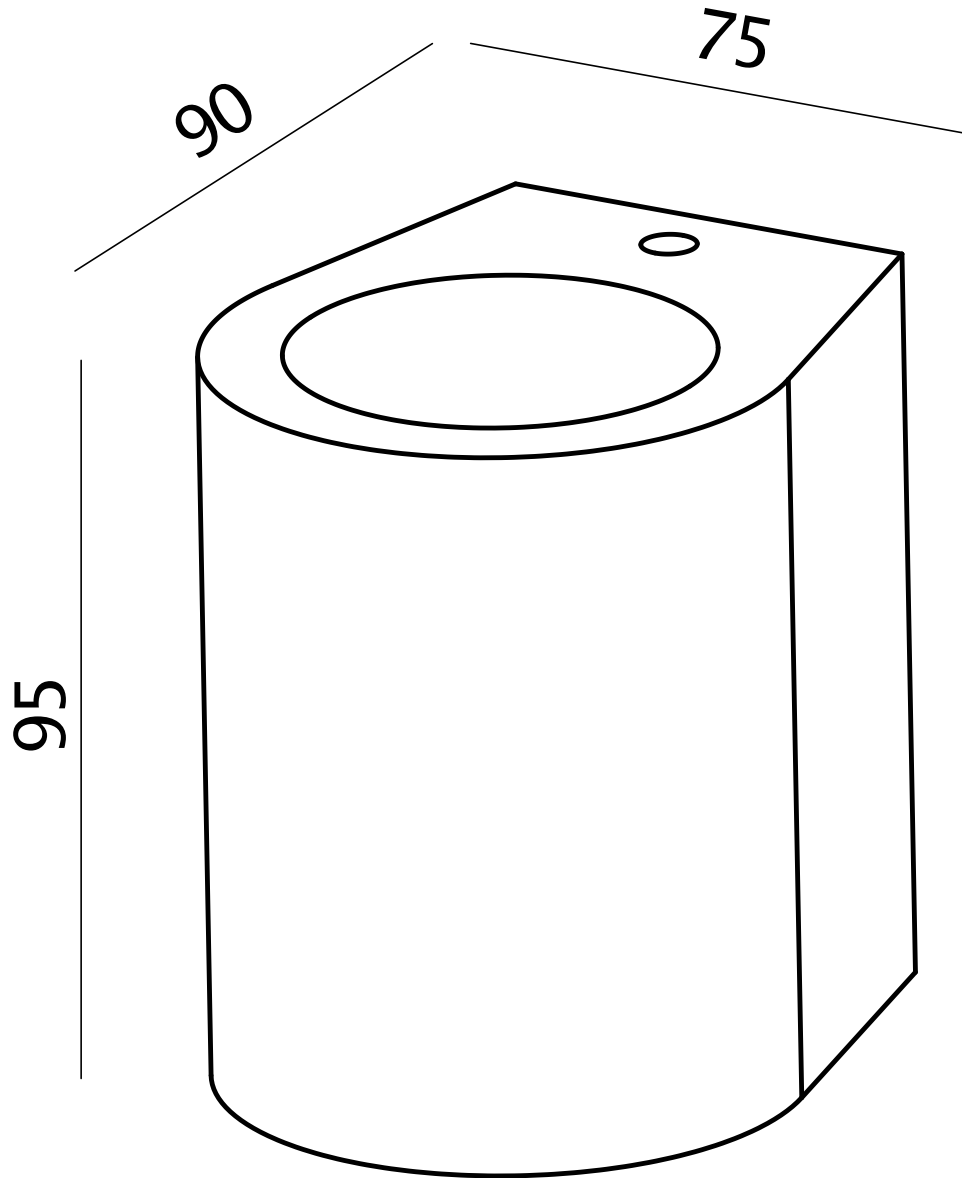

CERTIFICATION



CONTACT

www.firstchoicelighting.co.uk

info@firstchoicelighting.co.uk