



LIGHT SOURCE DATA

- 2 x 40W Max GU10 Halogen (required)
- Lamp direction - Upwards & Downwards
- Lamp shape - Reflector/Pear Shape
- Dimmable
- Energy class: Not applicable

DIMENSION DATA

- Height 240mm
- Width 120mm
- Depth 140mm

- Weight 1.30kg

SPECIFICATION

- Manufacturer warranty for 2 years from date of purchase
- White plaster
- IP20
- No
- Class II - Double Insulated, No Earth
- 240V
- Assembly required? No
- UKCA Marking, Energy Efficient, Energy Saving

CERTIFICATION



CONTACT

www.firstchoicelighting.co.uk

info@firstchoicelighting.co.uk

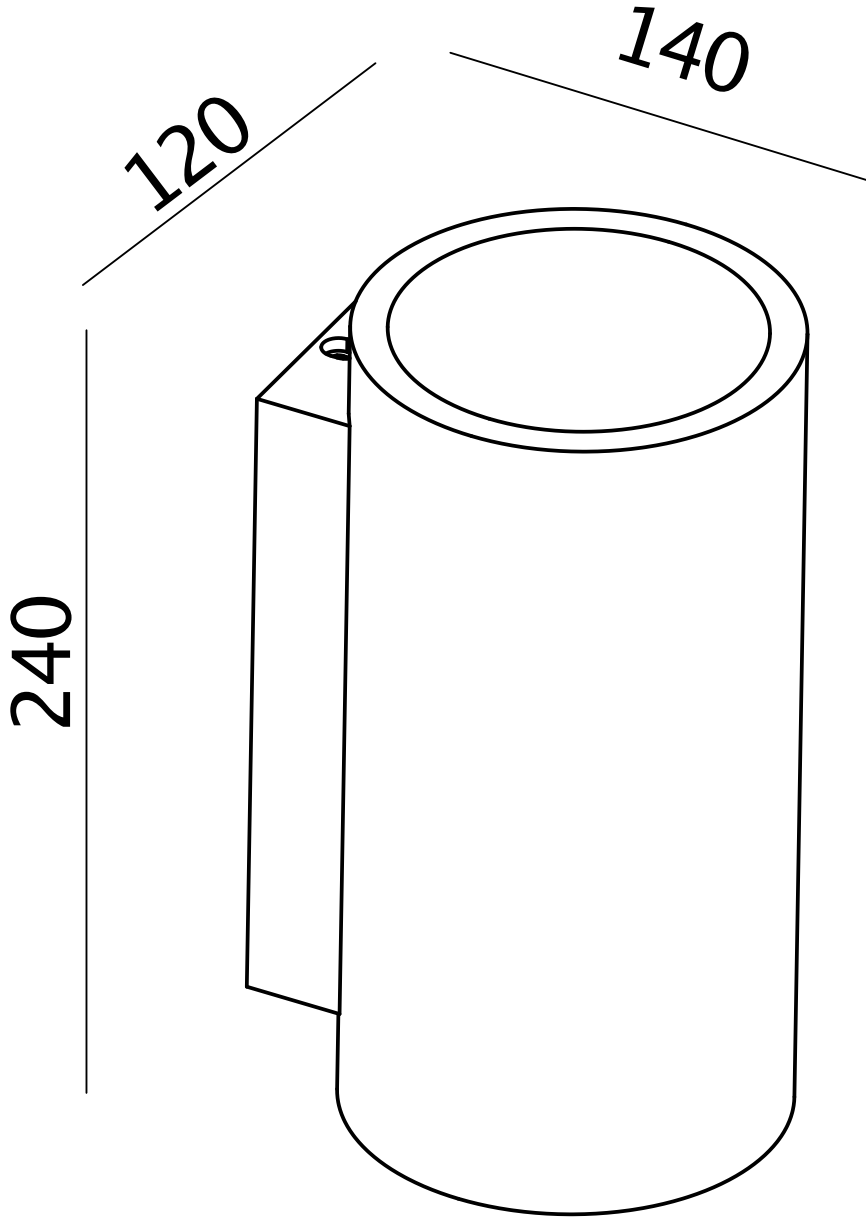

CERTIFICATION



CONTACT

www.firstchoicelighting.co.uk

info@firstchoicelighting.co.uk