

Set of 2 Sophia - White Plaster E27 Wall Lights



LIGHT SOURCE DATA

- 2 x 40W Max E27 ES (required)
- Lamp direction - Upwards & Downwards
- Lamp shape - Standard
- Dimmable
- Energy class: Not applicable

DIMENSION DATA

- Height 170mm
- Width 300mm
- Depth 130mm
- Weight 1.80kg

SPECIFICATION

- Manufacturer warranty for 2 years from date of purchase
- White plaster
- IP20
- No
- Class II - Double Insulated, No Earth
- 240V
- Assembly required? No
- UKCA Marking, Energy Efficient, Energy Saving

CERTIFICATION



CONTACT

www.firstchoicelighting.co.uk

info@firstchoicelighting.co.uk

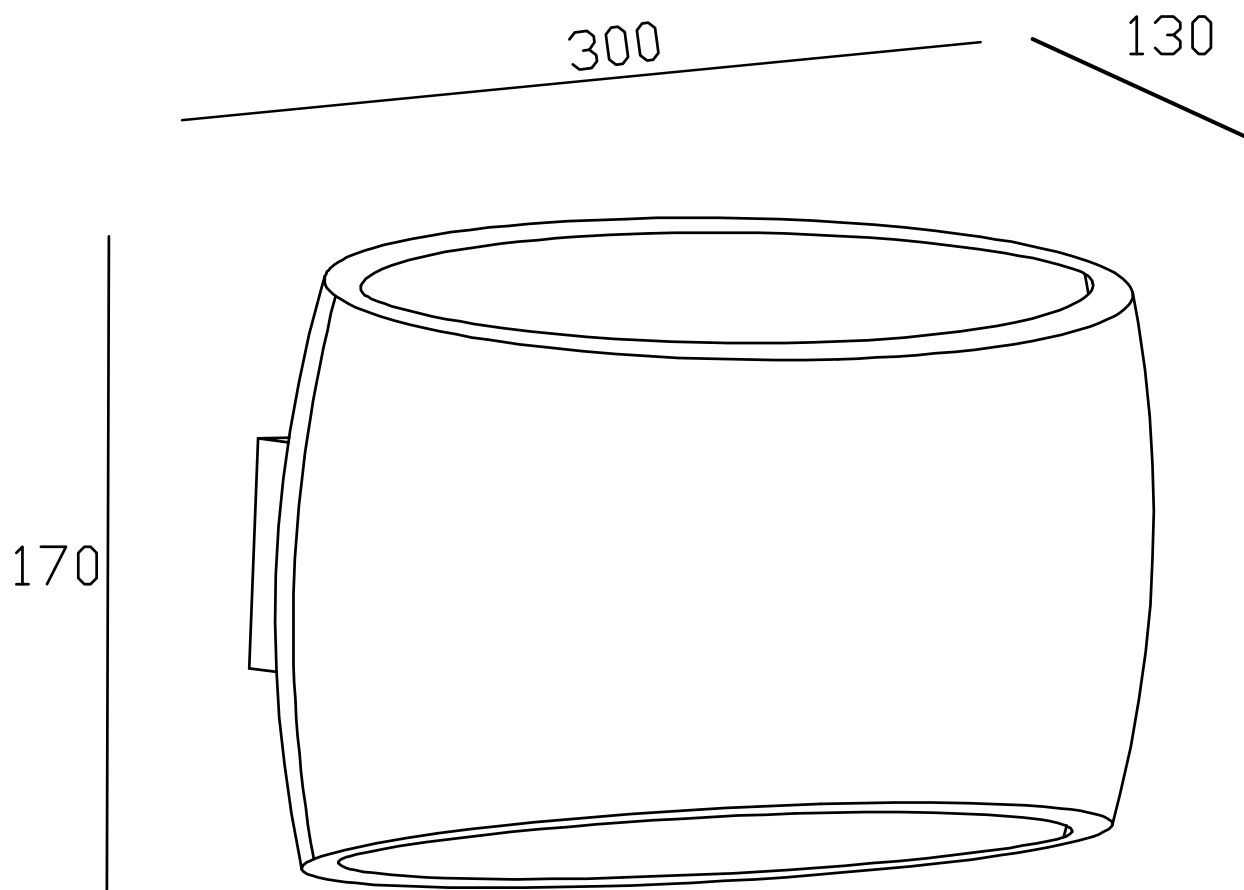

CERTIFICATION



CONTACT

www.firstchoicelighting.co.uk

info@firstchoicelighting.co.uk