

Evie - White Plaster GU10 Wall Light

---



## LIGHT SOURCE DATA

- 2 x 40W Max GU10 Halogen (required)
- Lamp direction - Upwards & Downwards
- Lamp shape - Reflector/Pear Shape
- Dimmable
- Energy class: Not applicable

## DIMENSION DATA

- Height 220mm
- Width 130mm
- Depth 88mm
  
- Weight 1.30kg

## SPECIFICATION

- Manufacturer warranty for 2 years from date of purchase
- White plaster
- IP20
- No
- Class II - Double Insulated, No Earth
- 240V
- Assembly required? No
- UKCA Marking, Energy Efficient, Energy Saving

## CERTIFICATION



## CONTACT

[www.firstchoicelighting.co.uk](http://www.firstchoicelighting.co.uk)

[info@firstchoicelighting.co.uk](mailto:info@firstchoicelighting.co.uk)

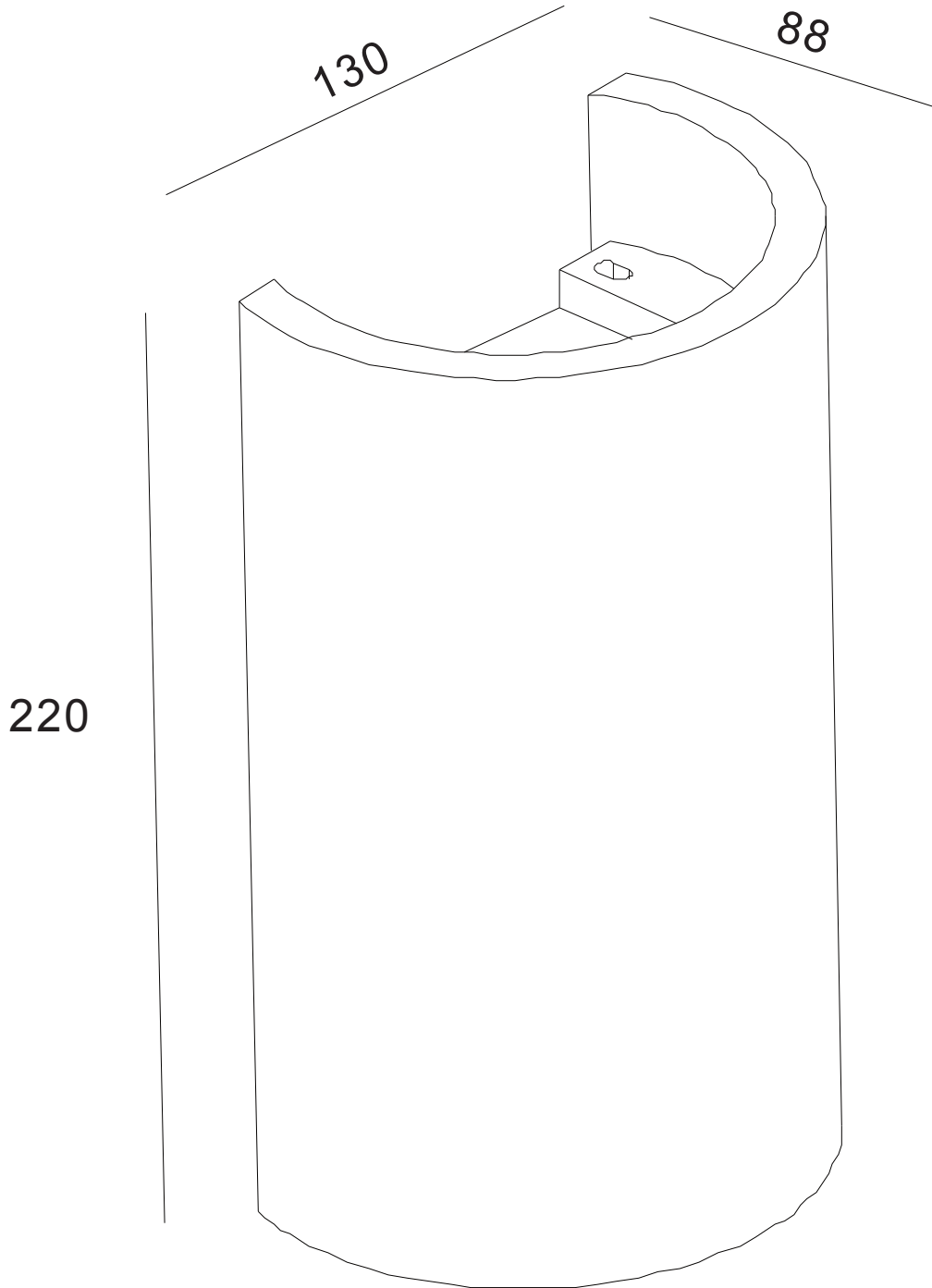

## CERTIFICATION



## CONTACT

[www.firstchoicelighting.co.uk](http://www.firstchoicelighting.co.uk)

[info@firstchoicelighting.co.uk](mailto:info@firstchoicelighting.co.uk)