

Set of 2 Jenson - Brushed Chrome 23cm Touch Table Lamp Bases



LIGHT SOURCE DATA

- 2 x 40W Max E14 SES (required)
- Lamp direction - Indirect
- Lamp shape - Conical/Candelabra/Candle
- Dimmer included
- Energy class: Not applicable

DIMENSION DATA

- Height 138mm
- Diameter 135mm

- Weight 0.32kg

SPECIFICATION

- Manufacturer warranty for 2 years from date of purchase
- Satin nickel plate
- IP20
- Touch 4 Stage Dimmer Switch
- Class II - Double Insulated, No Earth
- 240V
- Assembly required? No
- UKCA Marking, Energy Efficient, Energy Saving

CERTIFICATION



CONTACT

www.firstchoicelighting.co.uk

info@firstchoicelighting.co.uk

FCL-30590X2

Set of 2 Jenson - Brushed Chrome 23cm Touch Table Lamp Bases

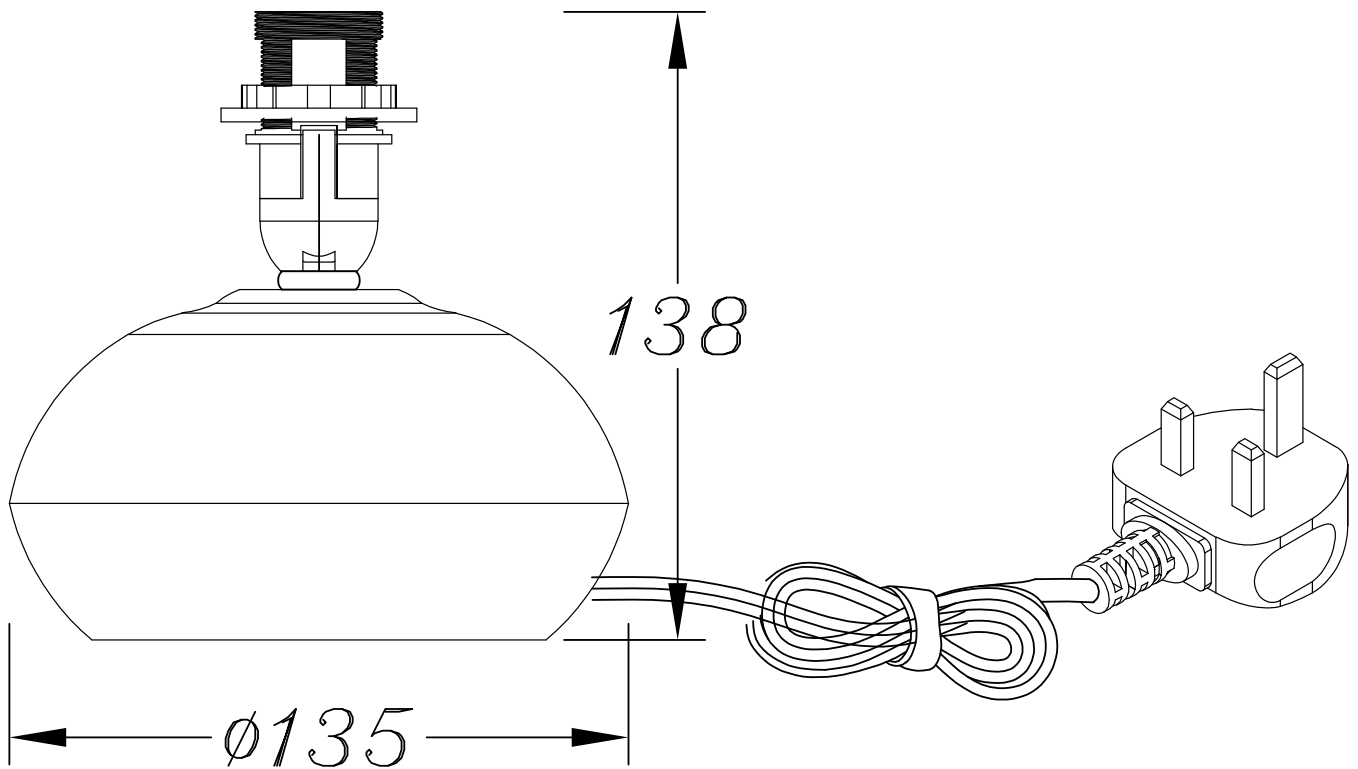

CERTIFICATION



CONTACT

www.firstchoicelighting.co.uk

info@firstchoicelighting.co.uk