

Set of 2 Jenson - Brushed Chrome Touch Table Lamps Sage Fern Shade



## LIGHT SOURCE DATA

- 2 x 40W Max E14 SES (required)
- Lamp direction - Indirect
- Lamp shape - Conical/Candelabra/Candle
- Dimmer included
- Energy class: Not applicable

## DIMENSION DATA

- Height 220mm
- Diameter 135mm
  
- Weight 0.32kg

## SPECIFICATION

- Manufacturer warranty for 2 years from date of purchase
- Satin nickel plate and sage green cotton
- IP20
- Touch 4 Stage Dimmer Switch
- Class II - Double Insulated, No Earth
- 240V
- Assembly required? No
- UKCA Marking, Energy Efficient, Energy Saving

## CERTIFICATION



## CONTACT

[www.firstchoicelighting.co.uk](http://www.firstchoicelighting.co.uk)

[info@firstchoicelighting.co.uk](mailto:info@firstchoicelighting.co.uk)

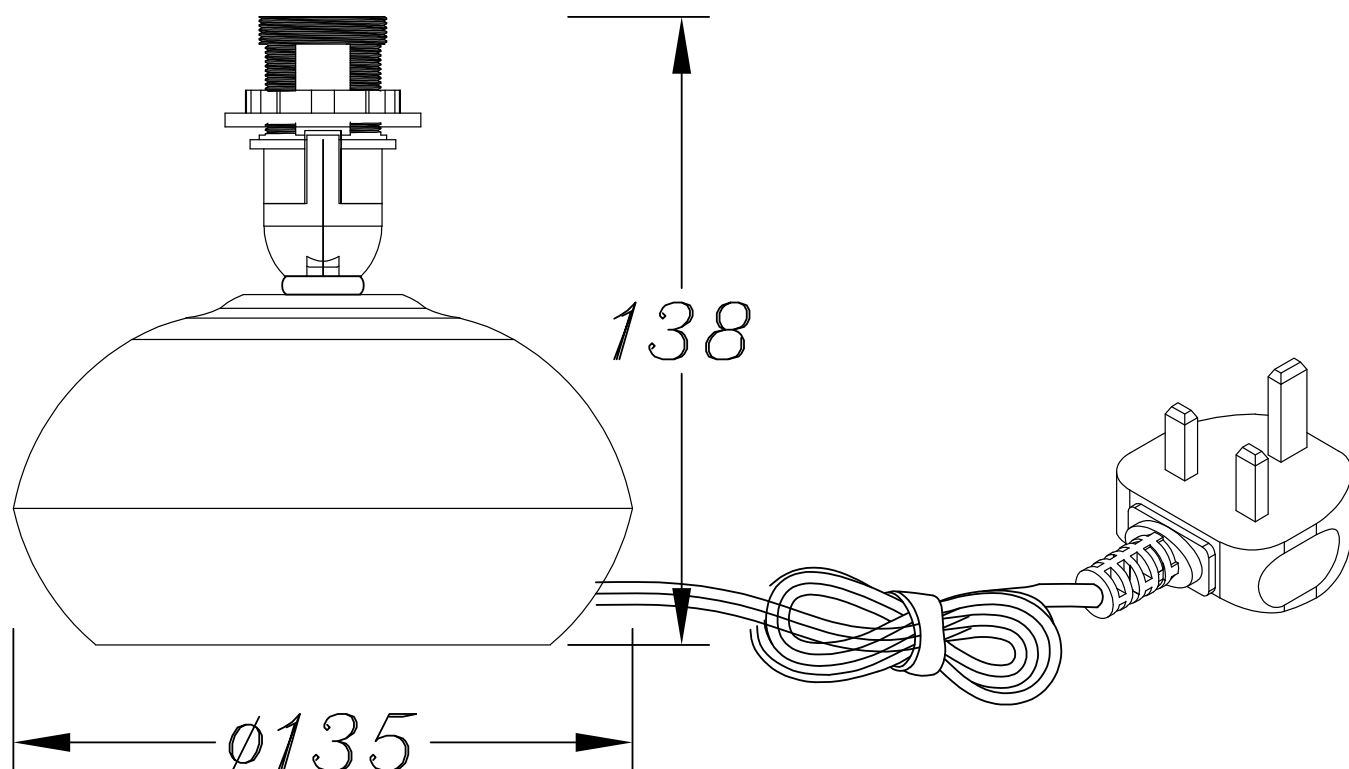

## CERTIFICATION



## CONTACT

[www.firstchoicelighting.co.uk](http://www.firstchoicelighting.co.uk)

[info@firstchoicelighting.co.uk](mailto:info@firstchoicelighting.co.uk)