



LIGHT SOURCE DATA

- 3 x 13W Max LED E27 ES (required)
- Lamp direction - Indirect
- Lamp shape - Standard
- Non-dimmable
- Energy class: Not applicable

DIMENSION DATA

- Height 1200mm
- Diameter 390mm

- Weight 2.70kg

SPECIFICATION

- Manufacturer warranty for 2 years from date of purchase
- Silver paint
- IP20
- No
- Class I - Single Insulated, Earthed
- 240V
- Assembly required? No
- UKCA Marking, Energy Efficient, Energy Saving

CERTIFICATION



CONTACT

www.firstchoicelighting.co.uk

info@firstchoicelighting.co.uk

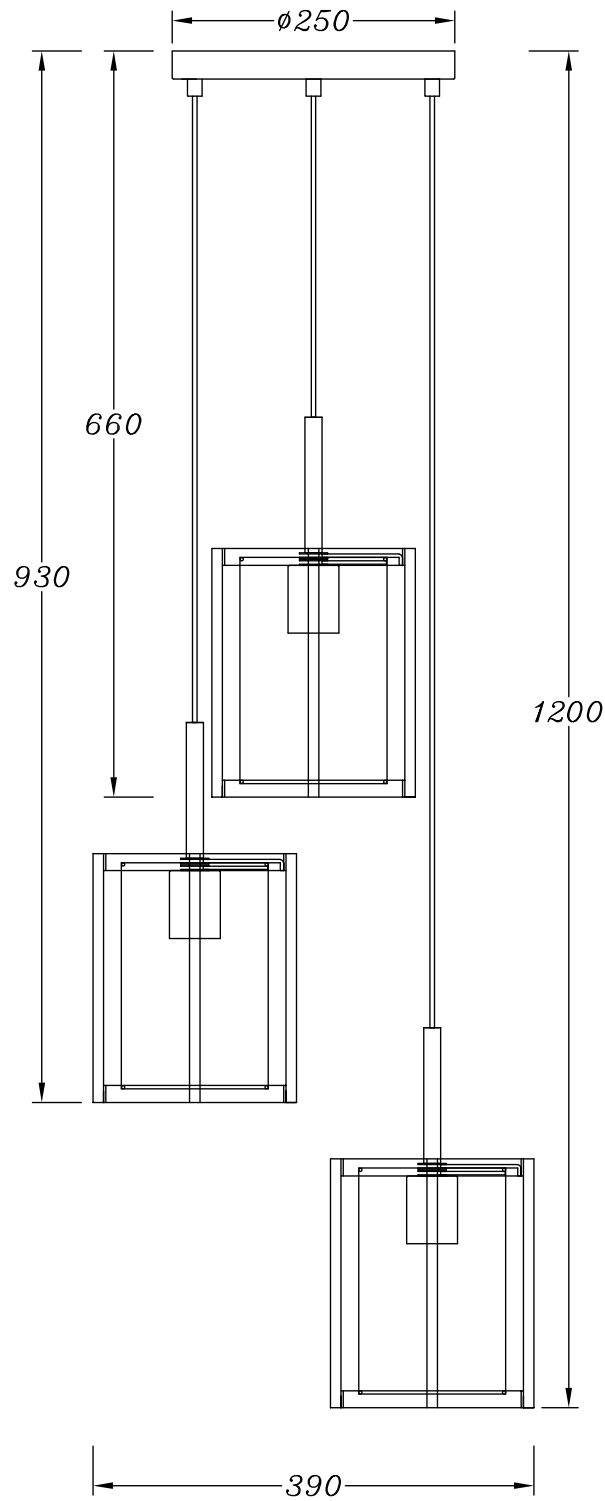

CERTIFICATION



CONTACT

www.firstchoicelighting.co.uk

info@firstchoicelighting.co.uk