

Set of 2 Antique Brass Stick Table Lamps with Teal Fern Cut Out Shades



LIGHT SOURCE DATA

- 2 x 7W Max LED E14 SES (required)
- Lamp direction - Indirect
- Lamp shape - Standard
- Non-dimmable
- Energy class: Not applicable

DIMENSION DATA

- Height 370mm
- Diameter 155mm

- Weight 1.05kg

SPECIFICATION

- Manufacturer warranty for 2 years from date of purchase
- Antique brass plate and teal cotton with silver inner detail
- IP20
- In-line On/Off Switch
- Class II - Double Insulated, No Earth
- 240V
- Assembly required? No
- UKCA Marking, Energy Efficient, Energy Saving

CERTIFICATION



CONTACT

www.firstchoicelighting.co.uk

info@firstchoicelighting.co.uk

Set of 2 Antique Brass Stick Table Lamps with Teal Fern Cut Out Shades

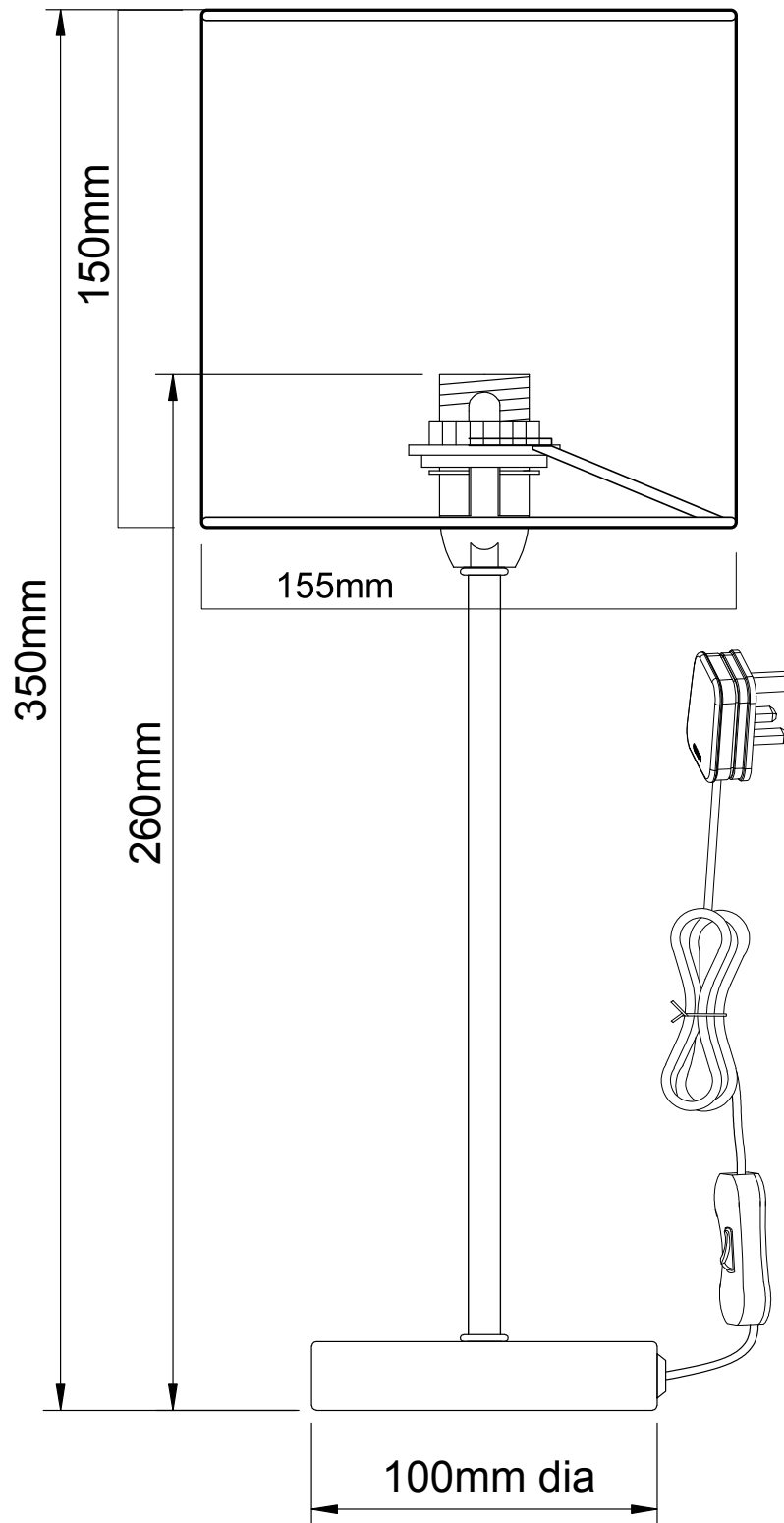

CERTIFICATION



CONTACT

www.firstchoicelighting.co.uk

info@firstchoicelighting.co.uk