

Set of 2 Antique Brass Stick Table Lamps with Ochre Fern Shades



## LIGHT SOURCE DATA

- 2 x 7W Max LED E14 SES (required)
- Lamp direction - Indirect
- Lamp shape - Standard
- Non-dimmable
- Energy class: Not applicable

## DIMENSION DATA

- Height 370mm
- Diameter 155mm
  
- Weight 1.05kg

## SPECIFICATION

- Manufacturer warranty for 2 years from date of purchase
- Antique brass plate and ochre cotton with silver inner detail
- IP20
- In-line On/Off Switch
- Class II - Double Insulated, No Earth
- 240V
- Assembly required? No
- UKCA Marking, Energy Efficient, Energy Saving

## CERTIFICATION



## CONTACT

[www.firstchoicelighting.co.uk](http://www.firstchoicelighting.co.uk)

[info@firstchoicelighting.co.uk](mailto:info@firstchoicelighting.co.uk)

# FCL-30787\_25656X2

Set of 2 Antique Brass Stick Table Lamps with Ochre Fern Shades

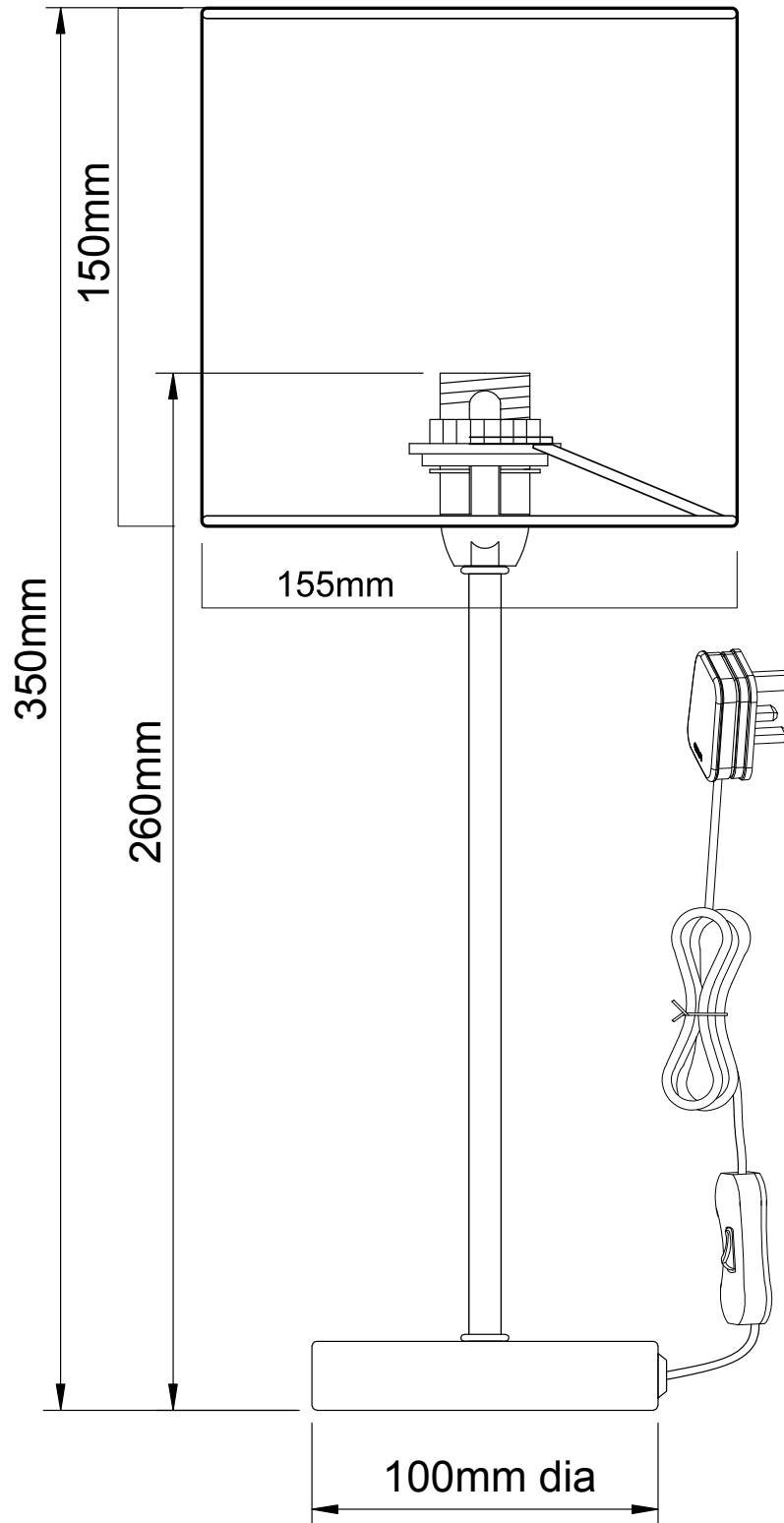

## CERTIFICATION



## CONTACT

[www.firstchoicelighting.co.uk](http://www.firstchoicelighting.co.uk)

[info@firstchoicelighting.co.uk](mailto:info@firstchoicelighting.co.uk)

ISSUE DATE 27/11/2025

PAGE 2