

## LIGHT SOURCE DATA

- 5W Max LED E27 ES (required)
- Lamp direction - Indirect
- Lamp shape - Standard
- Dimmable
- Energy class: Not applicable

## DIMENSION DATA

- Height 350 - 1000mm
- Diameter 250mm
- Weight 1.00kg

## SPECIFICATION

- Manufacturer warranty for 2 years from date of purchase
- Satin brass plate and white glass
- IP20
- No
- Class I - Single Insulated, Earthed
- 240V
- Assembly required? Yes
- UKCA Marking, Energy Efficient, Energy Saving

## CERTIFICATION



## CONTACT

[www.firstchoicelighting.co.uk](http://www.firstchoicelighting.co.uk)

[info@firstchoicelighting.co.uk](mailto:info@firstchoicelighting.co.uk)

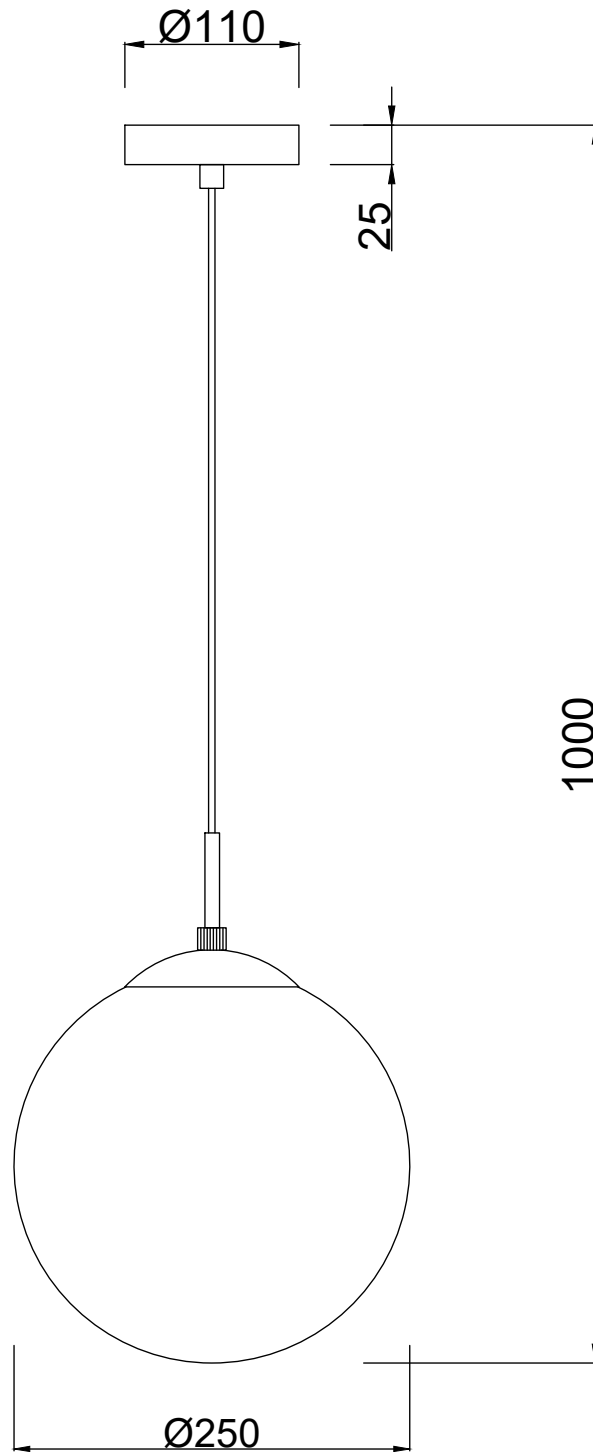

## CERTIFICATION



## CONTACT

[www.firstchoicelighting.co.uk](http://www.firstchoicelighting.co.uk)

[info@firstchoicelighting.co.uk](mailto:info@firstchoicelighting.co.uk)